

MX800 Model Number Configuration Guide

The MX800 build can be specified by the model number. The diagram below shows how the model number is derived from the wanted options. Consult Spectra for availability details on specific configurations and options.

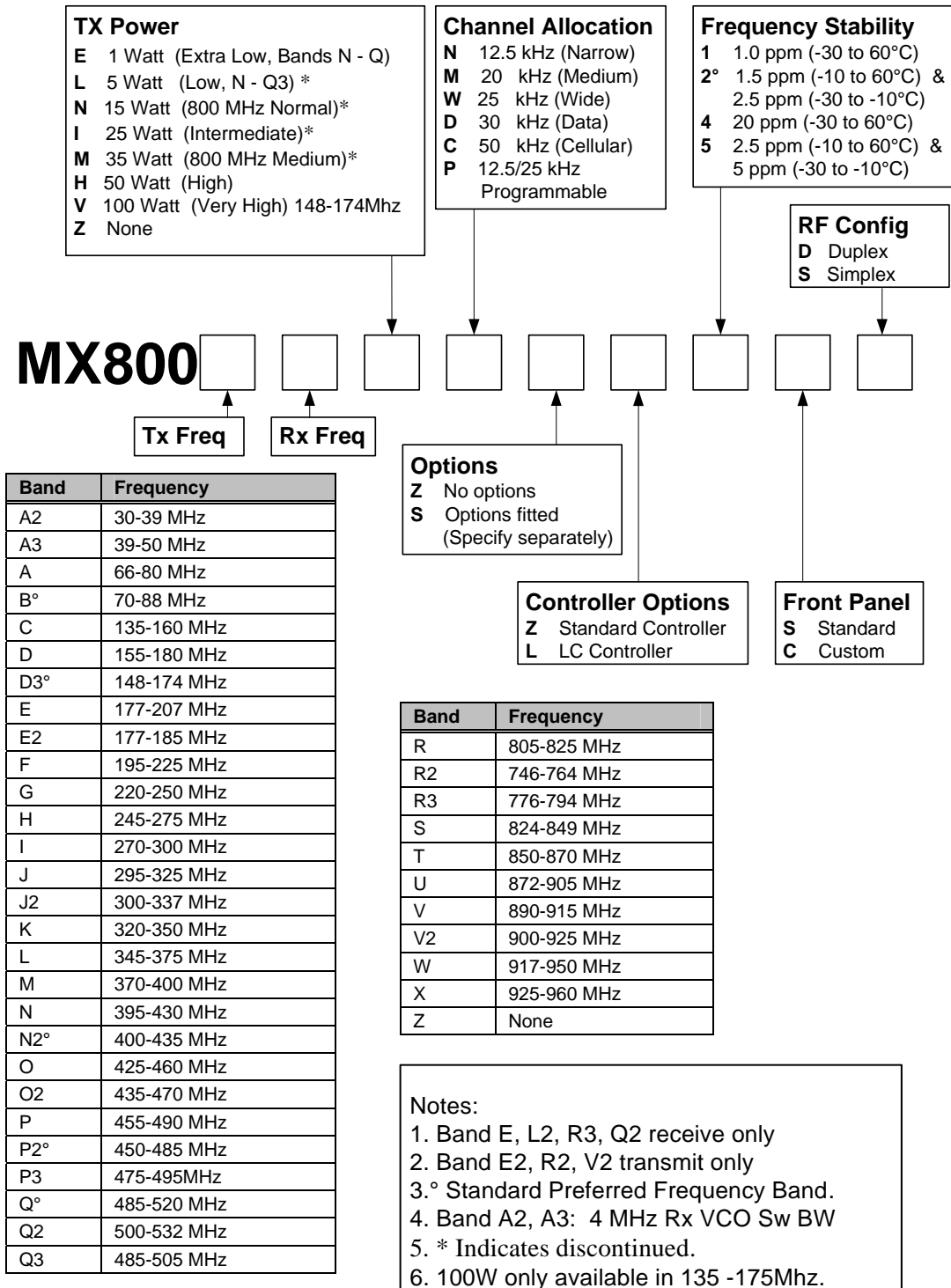

Due to ongoing development please refer to www.spectraeng.com.au for the latest revision of this document page.